

# FRIGIDAIRE

# User Manual

## FNGJ60JGUC



### CONTENTS

Safety information.....	2	Oven - Daily use .....	15
Safety instructions.....	5	Oven - Clock functions.....	17
Product description.....	9	Oven - Using the accessories.....	18
Before first use.....	10	Oven - Hints and tips.....	19
Hob - Daily use.....	11	Oven - Care and cleaning.....	23
Hob - Hints and tips.....	13	Troubleshooting.....	26
Hob - Care and cleaning.....	14	Installation.....	28

## SAFETY INFORMATION

Before the installation and use of the appliance, carefully read the supplied instructions. The manufacturer is not responsible for any injuries or damages that are the result of incorrect installation or usage. Always keep the instructions in a safe and accessible location for future reference.

### Children and vulnerable people safety

#### WARNING!

Risk of suffocation, injury or permanent disability.

- This appliance can be used by children aged from 8 years and above and persons with reduced physical, sensory or mental capabilities or lack of experience and knowledge if they have been given supervision or instruction concerning the use of the appliance in a safe way and understand the hazards involved.
- Children between 3 and 8 years of age and persons with very extensive and complex disabilities shall be kept away from the appliance unless continuously supervised.
- Children of less than 3 years of age should be kept away from the appliance unless continuously supervised.
- Do not let children play with the appliance.
- Keep all packaging away from children and dispose of it appropriately.
- Keep children and pets away from the appliance when it operates or when it cools down. Accessible parts may become hot during use.
- Children shall not carry out cleaning and user maintenance of the appliance without supervision.

### General Safety

- Only a qualified person must install this appliance and replace the cable.
- This appliance is intended for use up to an altitude of 2000 m above sea level.

- This appliance is not intended to be used on ships, boats or vessels.
- Do not install the appliance behind a decorative door in order to avoid overheating.
- Do not install the appliance on a platform.
- Do not operate the appliance by means of an external timer or separate remote-control system.
- **WARNING:** Unattended cooking on a hob with fat or oil can be dangerous and may result in fire.
- **NEVER** try to extinguish a fire with water, but switch off the appliance and then cover flame e.g. with a lid or a fire blanket.
- **CAUTION:** The cooking process has to be supervised. A short term cooking process has to be supervised continuously.
- **WARNING:** Danger of fire: Do not store items on the cooking surfaces.
- Do not use a steam cleaner to clean the appliance.
- Do not use harsh abrasive cleaners or sharp metal scrapers to clean the glass door or the glass of hinged lids of the hob since they can scratch the surface, which may result in shattering of the glass.
- Metallic objects such as knives, forks, spoons and lids should not be placed on the hob surface since they can get hot.
- Remove any spillage from the lid before opening. Let the hob surface cool down before closing the lid.
- **WARNING:** The appliance and its accessible parts become hot during use. Care should be taken to avoid touching heating elements.
- Always use oven gloves to remove or put in accessories or ovenware.
- Before maintenance, cut the power supply.
- **WARNING:** Ensure that the appliance is switched off before replacing the lamp to avoid the possibility of electric shock.

## SAFETY INFORMATION

- If the mains power supply cable is damaged, it must be replaced by the manufacturer, its Authorised Service Centre or similarly qualified persons to avoid an electrical hazard.
- **WARNING:** Use only hob guards designed by the manufacturer of the cooking appliance or indicated by the manufacturer of the appliance in the instructions for use as suitable or hob guards incorporated in the appliance. The use of inappropriate guards can cause accidents.

This appliance is suitable for the following markets: **BH** **IQ** **KW** **QA**

## Installation

### **WARNING!**

Only a qualified person must install this appliance.

- Remove all the packaging.
  - Do not install or use a damaged appliance.
  - Follow the installation instructions supplied with the appliance.
  - Always take care when moving the appliance as it is heavy. Always use safety gloves and enclosed footwear.
  - Do not pull the appliance by the handle.
  - The kitchen cabinet and the recess must have suitable dimensions.
  - Keep the minimum distance from other appliances and units.
  - Install the appliance in a safe and suitable place that meets installation requirements.
  - Parts of the appliance carry current. Close the appliance with furniture to prevent touching the dangerous parts.
  - The sides of the appliance must stay next to appliances or units with the same height.
  - Do not install the appliance adjacent to a door or under a window. This prevents hot cookware to fall from the appliance when the door or the window is opened.
- Always use a correctly installed shockproof socket.
  - Do not use multi-plug adapters and extension cables.
  - Do not let mains cables touch or come near the appliance door or the niche below the appliance, especially when it operates or the door is hot.
  - The shock protection of live and insulated parts must be fastened in such a way that it cannot be removed without tools.
  - Connect the mains plug to the mains socket only at the end of the installation. Make sure that there is access to the mains plug after the installation.
  - If the mains socket is loose, do not connect the mains plug.
  - Do not pull the mains cable to disconnect the appliance. Always pull the mains plug.
  - Use only correct isolation devices: line protecting cut-outs, fuses (screw type fuses removed from the holder), earth leakage trips and contactors.
  - The electrical installation must have an isolation device which lets you disconnect the appliance from the mains at all poles. The isolation device must have a contact opening width of minimum 3 mm.
  - Fully close the appliance door before you connect the mains plug to the mains socket.

## Electrical Connection

### **WARNING!**

Risk of fire and electric shock.

- All electrical connections should be made by a qualified electrician.
  - The appliance must be earthed.
  - Make sure that the parameters on the rating plate are compatible with the electrical ratings of the mains power supply.
- All gas connections should be made by a qualified person.
  - Before installation, make sure that the local distribution conditions (nature of the gas and gas pressure) and the adjustment of the appliance are compatible.
  - Make sure that there is air circulation around the appliance.
  - The information about the gas supply is on the rating plate.

# SAFETY INSTRUCTIONS

- This appliance is not connected to a device, which evacuates the products of combustion. Make sure to connect the appliance according to current installation regulations. Pay attention to requirements regarding adequate ventilation.

## Use

### WARNING!

Risk of injury and burns.  
Risk of electrical shock.

- This appliance is for household use only.
- Do not change the specification of this appliance.
- Make sure that the ventilation openings are not blocked.
- Do not let the appliance stay unattended during operation.
- Deactivate the appliance after each use.
- Be careful when you open the appliance door while the appliance is in operation. Hot air can release.
- Do not operate the appliance with wet hands or when it has contact with water.
- Do not use the appliance as a work surface or as a storage surface.

### WARNING!

Risk of fire and explosion

- Fats and oil when heated can release flammable vapours. Keep flames or heated objects away from fats and oils when you cook with them.
- The vapours that very hot oil releases can cause spontaneous combustion.
- Used oil, that can contain food remnants, can cause fire at a lower temperature than oil used for the first time.
- Do not put flammable products or items that are wet with flammable products in, near or on the appliance.

- Do not let sparks or open flames to come in contact with the appliance when you open the door.
- Open the appliance door carefully. The use of ingredients with alcohol can cause a mixture of alcohol and air.

### WARNING!

Risk of damage to the appliance.

- To prevent damage or discoloration to the enamel:
  - do not put ovenware or other objects in the appliance directly on the bottom.
  - do not put aluminium foil on the appliance or directly on the bottom of cavity.
  - do not put water directly into the hot appliance.
  - do not keep moist dishes and food in the appliance after you finish the cooking.
  - be careful when you remove or install the accessories.
- Discoloration of the enamel or stainless steel has no effect on the performance of the appliance.
- Use a deep pan for moist cakes. Fruit juices cause stains that can be permanent.
- Do not keep hot cookware on the control panel.
- Do not let cookware boil dry.
- Be careful not to let objects or cookware fall on the appliance. The surface can be damaged.
- Do not activate the cooking zones with empty cookware or without cookware.
- Cookware made of cast iron, aluminium or with a damaged bottom can cause scratches. Always lift these objects up when you have to move them on the cooking surface.
- Provide good ventilation in the room where the appliance is installed.
- Use only stable cookware with the correct shape and diameter larger than the dimensions of the burners.

# SAFETY INSTRUCTIONS

- Make sure the flame does not go out when you quickly turn the knob from the maximum to the minimum position.
- Use only the accessories supplied with the appliance.
- Do not install a flame diffuser on the burner.
- This appliance is for cooking purposes only. It must not be used for other purposes, for example room heating.

## Care and Cleaning

### **⚠ WARNING!**

Risk of injury, fire, or damage to the appliance.

- Before maintenance, deactivate the appliance.  
Disconnect the mains plug from the mains socket.
- Make sure the appliance is cold. There is the risk that the glass panels can break.
- Replace immediately the door glass panels when they are damaged. Contact the Authorised Service Centre.
- Be careful when you remove the door from the appliance. The door is heavy!
- Fat and food remaining in the appliance can cause fire.
- Clean regularly the appliance to prevent the deterioration of the surface material.
- Clean the appliance with a moist soft cloth. Only use neutral detergents. Do not use any abrasive products, abrasive cleaning pads, solvents or metal objects.
- If you use an oven spray, obey the safety instructions on the packaging.
- Do not clean the catalytic enamel (if applicable) with any kind of detergent.
- Do not clean the burners in the dishwasher.

## Lid

- Do not change the specification of the lid.
- Clean the lid regularly.

- Do not open the lid, when there are spills on the surface.
- Before you close the lid turn all burners off.
- Do not close the lid until the hob and oven are completely cold.
- Glass lid can shatter, when heated (if applicable).



- Keep the lid glass open, while the oven is in operation (if applicable).

## Internal lighting

### **⚠ WARNING!**

Risk of electric shock.

- Concerning the lamp(s) inside this product and spare part lamps sold separately: These lamps are intended to withstand extreme physical conditions in household appliances, such as temperature, vibration, humidity, or are intended to signal information about the operational status of the appliance. They are not intended to be used in other applications and are not suitable for household room illumination.
- Use only lamps with the same specifications.

## Gas Grill

### **⚠ WARNING!**

Risk of fire, explosion and burns.

- Do not leave the appliance unattended during grilling. Accessible parts become hot.
- Keep children away when the grill is in use.
- Do not put the oven shelf with food on the highest shelf level.

# SAFETY INSTRUCTIONS

## Service

- To repair the appliance contact the Authorised Service Centre.
- Use original spare parts only.

## Disposal

### **WARNING!**

Risk of injury or suffocation.

- Contact your municipal authority for information on how to discard the appliance correctly.
- Disconnect the appliance from the mains supply.
- Cut off the mains electrical cable close to the appliance and dispose of it.
- Remove the door catch to prevent children or pets from becoming trapped in the appliance.
- Flat the external gas pipes.



## General overview

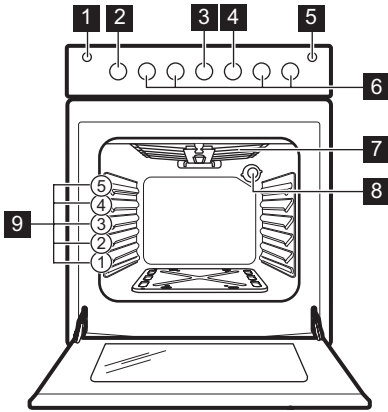

- 1 Button for the spark generator
- 2 Knob for the Minute Minder
- 3 Knob for the grill
- 4 Knob for the oven functions
- 5 Button for the lamp
- 6 Knobs for the hob
- 7 Grill
- 8 Lamp
- 9 Shelf positions

## Cooking surface layout

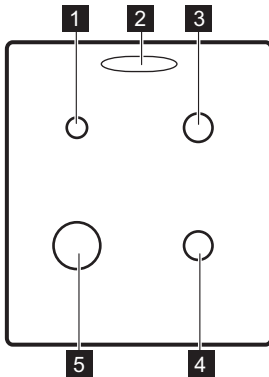

- 1 Auxiliary burner
- 2 Steam outlet - number and position depend on the model
- 3 Semi-rapid burner
- 4 Semi-rapid burner
- 5 Rapid burner

## Accessories

- **Wire shelf**  
For cookware, cake tins, roasts.
- **Baking tray**  
For cakes and biscuits.

# BEFORE FIRST USE

## **WARNING!**

Refer to Safety chapters.

## **Initial Cleaning**

Remove all accessories from the oven.

Refer to "Care and cleaning" chapter.

Clean the oven and the accessories before the first use.

Put the accessories back to their initial position.

## **Preheating**

Preheat the empty appliance to burn off the remaining grease.

1. Set the maximum temperature.
2. Let the appliance operate for approximately 1 hour.

## **WARNING!**

Accessories can become hotter than usual.

The appliance can emit an odour and smoke. This is normal. Make sure that the airflow is sufficient.

Let the oven cool down. Dampen a soft cloth with warm water and a little mild washing-up liquid and use this to clean the oven cavity.

## **⚠ WARNING!**

Refer to Safety chapters.

## **Ignition of the hob burner**

### **i**

Always light the burner before you put on the cookware.

## **⚠ WARNING!**

Be very careful when you use open fire in the kitchen environment. The manufacturer declines any responsibility in case of the flame misuse.



### **i**

The spark generator can start automatically when you switch on the mains, after installation or a power cut. It is normal.

### **i**

In the absence of electricity you can ignite the burner manually.

## **Ignition of a hob burner with the thermocouple**

- For manual ignition put the flame near the burner. Push the knob for the hob down and turn it counterclockwise to the maximum gas flow position .
- For ignition with spark generator button push and hold the spark generator button . At the same time push the knob for the hob down and turn it counterclockwise to the maximum gas flow position . Release the spark generator button when burner lights.

Keep the knob for the hob pushed for equal or less than 10 seconds to let the thermocouple warm up. If not, the gas supply is interrupted.

Adjust the flame after it is regular.

## **⚠ WARNING!**

Do not keep the knob pushed for more than 15 seconds. If the burner does not light after 15 seconds, release the knob, turn it into the off position and try to light the burner again after minimum 1 minute.

### **i**

If after some tries the burner does not light, check if the crown and its cap are in the correct position.

### **i**

If the burner accidentally goes out, turn the knob to the off position and try to light the burner again after minimum 1 minute.

## **Burner overview**

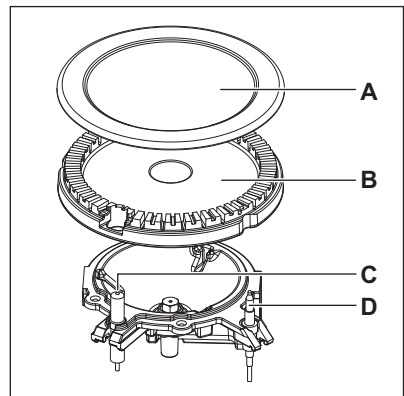

- A.** Burner cap
- B.** Burner crown
- C.** Ignition candle
- D.** Thermocouple (if applicable)

## HOB - DAILY USE

### Turning the burner off

To put the flame out, turn the knob to the off position ●.

#### **WARNING!**

Always turn the flame down or switch it off before you remove the pans from the burner.

## WARNING!

Refer to Safety chapters.

## Cookware

### WARNING!

Do not put the same pan on two burners.

### WARNING!

Do not put unstable or damaged pots on the burner to prevent spills and injuries.

### CAUTION!

Make sure that pot handles are not above the front edge of the cooktop.

### CAUTION!

Make sure that the pots are placed centrally on the burner in order to get the maximum stability and a lower gas consumption.

## Diameters of cookware

### WARNING!

Use cookware with diameters applicable to the size of burners.

BURNER	DIAMETER OF COOKWARE (MM)
Rapid	160 - 260
Semi-rapid	140 - 240
Auxiliary	120 - 180

## Energy saving

- If it is possible, always put the lids on the cookware.
- When the liquid starts to boil, turn down the flame to barely simmer the liquid.

# HOB - CARE AND CLEANING

## **⚠ WARNING!**

Refer to Safety chapters.

## **General information**

- Clean the hob after each use.
- Always use cookware with a clean base.
- Scratches or dark stains on the surface have no effect on how the hob operates.
- Use a special cleaner suitable for the surface of the hob.
- Wash stainless steel parts with water, and then dry them with a soft cloth.

## **Cleaning the hob**

- **Remove immediately:** melted plastic, plastic foil, sugar and food with sugar, otherwise, the dirt can cause damage to the hob. Take care to avoid burns.
- **Remove when the hob is sufficiently cool:** limescale rings, water rings, fat stains, shiny metallic discoloration. Clean the hob with a moist cloth and a non-abrasive detergent. After cleaning, wipe the hob dry with a soft cloth.
- To clean the enamelled parts, caps and crowns, wash them with warm soapy water and dry them carefully before you put them back on.

## **Cleaning the spark plug**

This feature is obtained through a ceramic ignition candle with a metal electrode. Keep these components well clean to prevent difficult lighting and check that the burner crown holes are not obstructed.

## **Pan supports**

### **i**

The pan supports are not resistant to washing in a dishwasher. They must be washed by hand.

1. Remove the pan supports to easily clean the hob.

### **i**

Be very careful when you replace the pan supports to prevent the hob top from damage.

2. The enamel coating occasionally can have rough edges, so be careful when you wash the pan supports by hand and dry them. If necessary, remove stubborn stains with a paste cleaner.
3. After you clean the pan supports, make sure that they are in correct positions.
4. For the burner to operate correctly, make sure that the arms of the pan supports are aligned with the centre of the burner.



## **Periodic maintenance**

Speak to your local Authorised Service Centre periodically to check the conditions of the gas supply pipe and the pressure adjuster, if fitted.

## ⚠ WARNING!

Refer to Safety chapters.

## Oven Functions

OVEN FUNCTION		APPLICATION
●	Off position	The oven is off.
MIN - 240°C	Heat settings	Range of temperature adjustment.
	Grilling	To grill flat food in the middle of the grill. To make toast.
	Oven lamp	To illuminate the oven interior. To use this function, press the button for the lamp.

## Ignition of the oven gas burner

### ⚠ CAUTION!

When turning on the oven burner the oven door must be opened.

### ⚠ CAUTION!

Make sure that the lid is opened.  
When using the oven the lid has to be opened to avoid over-heating.



### Oven safety device:

The gas oven has a thermocouple. It stops the gas flow if the flame goes out.

1. Open the oven door.
2. Ignite the oven gas burner.
  - For ignition on the spark generator button push and hold the button . At the same time turn the knob for the oven functions counterclockwise to the maximum heat settings and push it to light the burner. Release the spark generator button when burner lights.

Keep the knob for the oven functions pushed for 15 seconds or less to let the thermocouple warm up. If not, the gas flow is interrupted.

## Manual ignition of oven gas burner

In case of absence of the electricity you can ignite the oven burner without an electrical device.

1. Open the oven door.
2. Hold the flame near the hole in the bottom of the oven cavity.

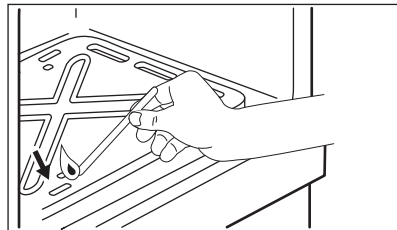

3. At the same time push the knob for the oven functions and turn it counterclockwise to the maximum gas flow position.
4. When the flame comes on, keep the knob for the oven functions pushed on

## OVEN - DAILY USE

the maximum gas flow position for 15 seconds or less to let the thermocouple warm up.



Do not keep the knob for the oven functions pushed for more than 15 seconds. If the oven burner does not light after 15 seconds, release the knob for the oven functions, turn it into off position, open the oven door and try to light the oven burner again after minimum 1 minute.

### After igniting the oven gas burner

1. Release the knob for the oven functions.
2. Close the oven door.
3. Turn the knob for the oven functions to set the necessary heat setting.

Control the flame through the holes in the bottom of the oven.

### Turning off the oven burner

To put out the flame, turn the knob to the off position ●.

### Using the grill

#### CAUTION!

Always keep the appliance door closed when the grill operates.



Do not put the meat directly on the tray or pan.

#### CAUTION!

Do not put the meat on the highest shelf level. There is a risk of fire.

1. Open the oven door.
2. Ignite the grill burner.

- For manual ignition hold a flame near the grill burner holes. Push and turn the knob for the grill to the flame position. Hold the knob pushed down.
  - For ignition on the spark generator button push and hold the spark generator button. Push and turn the knob for the grill to the flame position. Hold the knob pushed. Release the spark generator button when burner lights.
3. Hold the knob for the grill pushed for approximately 15 seconds.
  4. Release the oven control knob. The grill temperature can be adjusted. To lower the temperature turn the knob for the grill counterclockwise. If the grill does not come on or if it accidentally goes out release the knob for the oven functions and turn it to the Off position. Open the oven door. After one minute, try to light the grill again.
  5. Preheat the grill for 5 to 10 minutes.
  6. Put the oven shelf with the meat on shelf position 3.
  7. Put a baking tray or roasting pan below, on shelf position 2, to collect the juices.

If there is temporarily no power supply open the oven door hold a flame near the grill burner holes and turn the knob for the gas to the flame position.

### Turning off the grill burner

To put out the flame, turn the knob to the off position ●.



### Minute Minder



This function has no effect on the operation of the appliance.

Turn the knob for the timer as far as it goes, then turn it to necessary time period. After the time period is completed, an acoustic signal sounds.

## OVEN - USING THE ACCESSORIES

### **⚠ WARNING!**

Refer to Safety chapters.

### **Inserting the accessories**

Wire shelf:

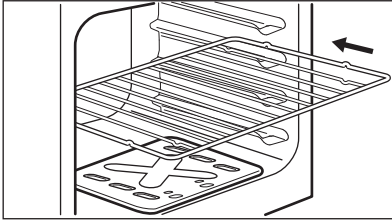

Put the shelf on the correct shelf position. Make sure it does not touch the back wall of the oven.

Tray:

### **i**

Do not push the baking tray all the way to the back wall of the cavity. This prevents the heat from circulating around the tray. The food may be burnt, especially in the rear part of the tray.

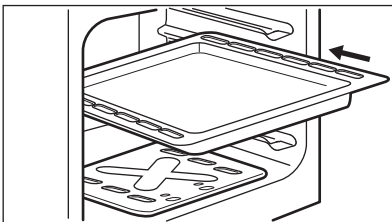

Put the tray or deep pan on the shelf position. Make sure it does not touch the back wall of the oven.

## **⚠ WARNING!**

Refer to Safety chapters.

## **i**

The temperature and baking times in the tables are guidelines only. They depend on the recipes and the quality and quantity of the ingredients used.

## General information

- The appliance has five shelf positions. Count the shelf positions from the bottom of the appliance floor.
- Moisture can condense in the appliance or on the door glass panels. This is normal. Always stand back from the appliance when you open the appliance door while cooking. To decrease the condensation, operate the appliance for 10 minutes before cooking.
- Clean the moisture after each use of the appliance.
- Do not put the objects directly on the appliance floor and do not put aluminium foil on the components when you cook. This can change the baking results and cause damage to the enamel.

## Baking

Use the lower temperature the first time.

## Cooking tables

Casseroles

FOOD	QUANTITY (KG)	TEMPERATURE (°C)	TIME (MIN)	GRILL POSITION	GRILLING TIME (MIN)	TOTAL PREPARATION TIME (MIN)	SHELF POSITION
Lasagna <sup>1)</sup>	1.5 - 2.5	195	35 - 40	min.	35 - 40	35 - 40	2
Cannelloni <sup>1)</sup>	1.5 - 2.5	195	35 - 40	min.	35 - 40	35 - 40	2

You can extend baking times by 10 – 15 minutes if you bake cakes on more than one shelf position.

Trays in the oven can twist during baking. When the trays become cold again, the distortions disappear.

## Baking cakes

Do not open the oven door before 3/4 of the set cooking time is up.

## Cooking meat and fish

Leave the meat for approximately 15 minutes before carving so that the juice does not seep out.

To prevent too much smoke in the oven during roasting, add some water into the deep pan. To prevent the smoke condensation, add water each time after it dries up.

## Cooking times

Cooking times depend on the type of food, its consistency, and volume.

Initially, monitor the performance when you cook. Find the best settings (heat setting, cooking time, etc.) for your cookware, recipes and quantities when you use this appliance.

## OVEN - HINTS AND TIPS

FOOD	QUANTITY (KG)	TEMPERATURE (°C)	TIME (MIN)	GRILL POSITION	GRILLING TIME (MIN)	TOTAL PREPARATION TIME (MIN)	SHELF POSITION
Potato gratin 1)	1.5 - 2.5	165	65 - 70	min.	10 - 15	65 - 70	2
Macaroni oven 1)	1.5 - 2.5	195	35 - 40	min.	35 - 40	35 - 40	2
Kebab Hala	1.5 - 2.5	195	30 - 35	max.	30 - 35	30 - 35	2

1) Preheat the oven for 10 minutes.

### Meat & Poultry

FOOD	QUANTITY (KG)	TEMPERATURE (°C)	TIME (MIN)	GRILL POSITION	GRILLING TIME (MIN)	TOTAL PREPARATION TIME (MIN)	SHELF POSITION
Sheep	1.5 - 2.0	210	90 - 120	max.	90 - 120	90 - 120	2
Chicken	1.0 - 1.8	240	75 - 80	max.	75 - 80	75 - 80	2
Duck	1.8 - 2.5	240	90 - 100	max.	90 - 100	90 - 100	2
Goose	2.5 - 3.0	225	100 - 120	max.	100 - 120	100 - 120	2
Rabbit	1.0 - 1.5	195	90 - 120	min.	90 - 120	90 - 120	2
Beef	1.2 - 1.8	210	90 - 120	min.	90 - 120	90 - 120	2

## OVEN - HINTS AND TIPS

### Fish

FOOD	QUANTITY (KG)	TEMPERATURE (°C)	TIME (MIN)	GRILL POSITION	GRILLING TIME (MIN)	TOTAL PREPARATION TIME (MIN)	SHELF POSITION
Pike	0.8 - 1.5	180	60 - 80	min.	60 - 80	60 - 80	2
Dorade	0.4 - 0.7	180	40 - 60	min.	40 - 60	40 - 60	2
Trout	0.5 - 1.0	180	25 - 30	min.	25 - 30	25 - 30	2

### Pizza

FOOD	QUANTITY (KG)	TEMPERATURE (°C)	TIME (MIN)	GRILL POSITION	GRILLING TIME (MIN)	TOTAL PREPARATION TIME (MIN)	SHELF POSITION
Thin 1)	1.0 - 1.2	240	20 - 25	min.	5 - 10	20 - 25	1
Thick 1)	1.4 - 1.5	240	25 - 30	min.	5 - 10	25 - 30	1
Calzone 1)	1.4 - 1.5	210	30 - 35	min.	5 - 10	30 - 35	2

1) Preheat the oven for 10 minutes.

### Cakes

FOOD	QUANTITY (KG)	TEMPERATURE (°C)	TIME (MIN)	GRILL POSITION	GRILLING TIME (MIN)	TOTAL PREPARATION TIME (MIN)	SHELF POSITION
Flat cake 1)	0.6 - 1.0	180	30 - 35	min.	5 - 10	30 - 35	2
Sponge cake	1.0 - 1.5	180	90 - 95	-	-	90 - 95	2
Feter Mshalted 1)	1.2 - 1.5	210	45 - 50	min.	5 - 10	45 - 50	2

## OVEN - HINTS AND TIPS

FOOD	QUANTITY (KG)	TEMPERATURE (°C)	TIME (MIN)	GRILL POSITION	GRILLING TIME (MIN)	TOTAL PREPARATION TIME (MIN)	SHELF POSITION
Salty cake <sup>1)</sup>	1.0 - 1.2	195	50 - 60	-	-	50 - 60	2
Yeast cake <sup>1)</sup>	1.0 - 1.5	195	45 - 50	min.	5 - 10	45 - 50	2

<sup>1)</sup> Preheat the oven for 10 minutes.

### Grilling

FOOD	QUANTITY (KG)	GRILL POSITION	TIME (MIN)	SHELF POSITION
Sheep chops <sup>1)</sup>	0.7 - 1.2	half	20 - 25	3
Ribs <sup>1)</sup>	1.0 - 1.2	half	45 - 60	3
Burgers <sup>1)</sup>	2.0 - 2.5	max.	15 - 20	3
Mackerel <sup>1)</sup>	1.2 - 1.5	half	20 - 25	3
Toast browning <sup>1)</sup>	0.5 - 0.8	max.	5 - 6	3
Toast Hawai <sup>1)</sup>	0.5 - 1.0	max.	15 - 20	3

<sup>1)</sup> Preheat the oven for 5 minutes.

## **⚠ WARNING!**

Refer to Safety chapters.

## **Notes on cleaning**

Clean the front of the oven with a soft cloth with warm water and a mild cleaning agent.

To clean metal surfaces, use a dedicated cleaning agent.

Clean the oven interior after each use. Fat accumulation or other food remains may result in a fire.

Clean all accessories after each use and let them dry. Use a soft cloth with warm water and a cleaning agent. Do not clean the accessories in the dishwasher.

Clean stubborn stains with a special oven cleaner.

If you have nonstick accessories, do not clean them using aggressive agents, sharp-edged objects or a dishwasher. It can cause damage to the nonstick coating.

Clean the moisture from the cavity after each use.

## **Stainless steel or aluminium ovens**

Clean the oven door with a damp cloth or sponge only. Dry it with a soft cloth.

Do not use steel wool, acids or abrasive materials as they can damage the oven surface. Clean the oven control panel with the same precautions.

## **Cleaning the oven door**

The oven door has two panels of glass installed one behind the other. To make the cleaning easier remove the oven door.

## **⚠ WARNING!**

The oven door can close if you try to remove the internal panel of glass when the door is still assembled.



Do not loosen the screws.

1. Open the door fully.

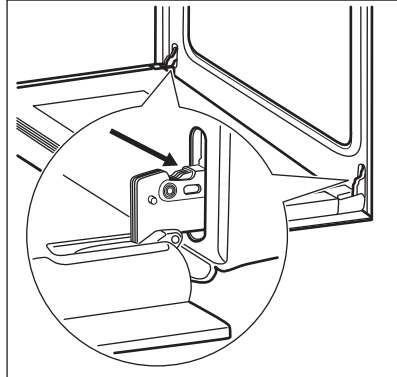

2. Lift and turn the levers on the two hinges till they stop (until you reach the pins).

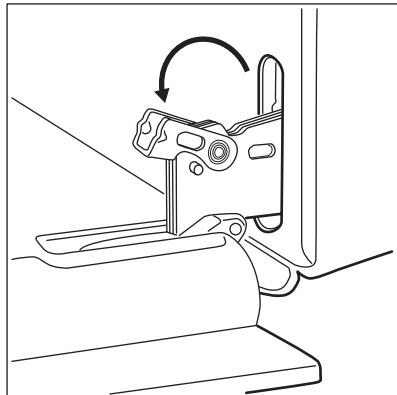

## OVEN - CARE AND CLEANING

**i**

Avoid placing the levers in the vertical position and make sure both of them are pulled maximally towards you.

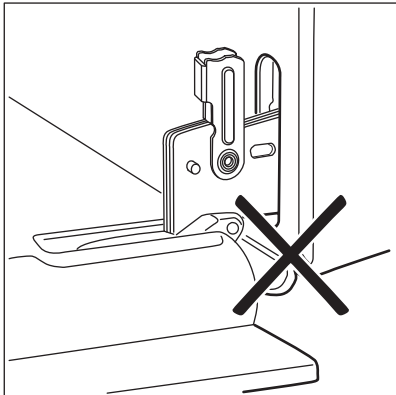

3. Close the oven door to the first opening position (halfway). Then pull forward and remove the door from its seat.

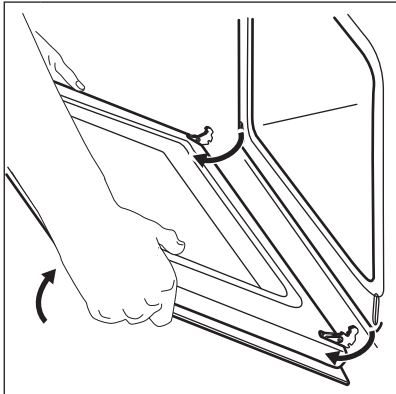

4. Put the door on a soft cloth on a stable surface.  
5. Use a screwdriver to remove the 2 screws from the bottom edge of the door.

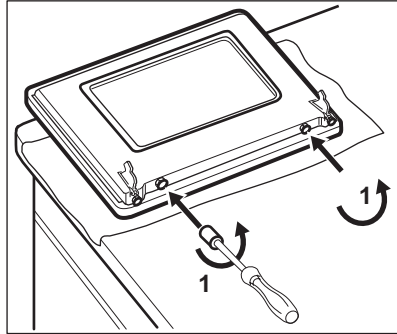

6. Use a spatula made of wood or plastic (or equivalent) to open the inner door. Hold the outer door, and push the inner door against the top edge of the door. Lift the inner door.

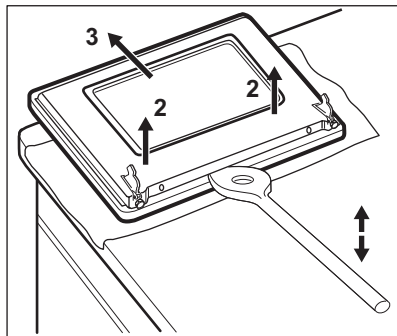

7. Clean the oven door with water and soap. Clean the inner side of the door. Dry the oven door carefully. When the cleaning is completed, install the glass panels and the oven door. To install the oven door, do the above steps in the opposite sequence.



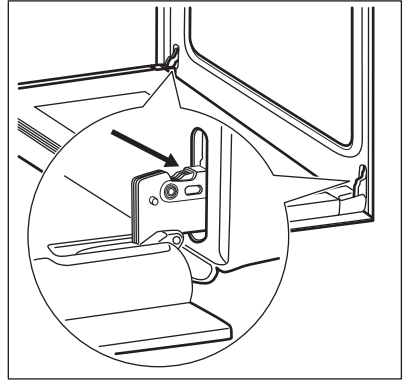
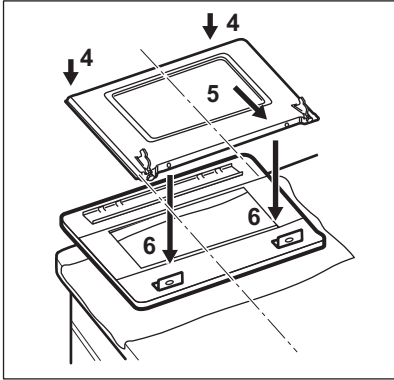

Make sure the slot in the hinge A rests on the edge of the hinge support B before releasing the oven door.

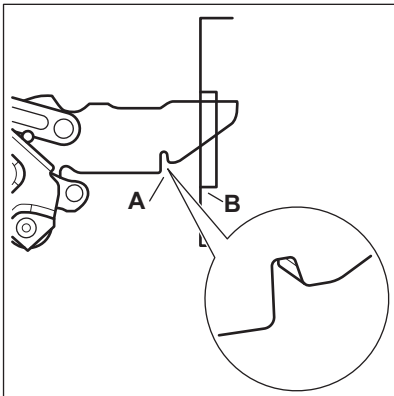

Make sure the levers are in their original position before closing the door.

## Replacing the lamp

### WARNING!

Risk of electric shock.  
The lamp can be hot.

1. Turn off the oven.  
Wait until the oven is cooled down.
2. Disconnect the oven from the mains.
3. Put a cloth on the bottom of the cavity.

### The back lamp

1. Turn the lamp glass cover to remove it.
2. Clean the glass cover.
3. Replace the lamp with a suitable 300 °C heat-resistant lamp.
4. Install the glass cover.

## TROUBLESHOOTING

### WARNING!

Refer to Safety chapters.

### What to do if...

PROBLEM	POSSIBLE CAUSE	REMEDY
There is no spark when you try to activate the spark generator.	The hob is not connected to an electrical supply or it is connected incorrectly.	Check if the hob is correctly connected to the electrical supply. Refer to the connection diagram.
There is no spark when you try to activate the spark generator.	The fuse is blown.	Make sure that the fuse is the cause of the malfunction. If the fuse is blown again and again, contact a qualified electrician.
There is no spark when you try to activate the spark generator.	Burner cap and crown are placed incorrectly.	Place the burner cap and crown correctly.
The flame extinguishes immediately after ignition.	Thermocouple is not heated up sufficiently.	After lighting the flame, keep the spark generator activated for equal or less than 10 seconds
The flame ring is uneven.	Burner crown is blocked with food residues.	Make sure that the injector is not blocked and the burner crown is clean.
The burners do not work.	There is no gas supply.	Check the gas connection.
The appliance makes noises.		Some metal parts of the appliance expand and contract when they heat up or cool down. The noises are normal.
The flame colour is orange or yellow.		The flame can look orange or yellow in some areas of the burner. This is normal.
The lamp does not operate.	The lamp is defective.	Replace the lamp.
Steam and condensation settle on the food and in the cavity of the oven.	You left the dish in the oven for too long.	Do not leave the dishes in the oven for longer than 15 - 20 minutes after the cooking process ends.

PROBLEM	POSSIBLE CAUSE	REMEDY
The oven does not heat up.	The necessary settings are not set.	Make sure that the settings are correct.
It takes too long to cook the dishes or they cook too quickly.	The temperature is too low or too high.	Adjust the temperature if necessary. Follow the advice in the user manual.

## Service data

If you cannot find a solution to the problem yourself, contact your dealer or an Authorised Service Centre.

The necessary data for the service centre is on the rating plate. The rating plate is on

the front frame of the oven cavity. Do not remove the rating plate from the oven cavity.

## WE RECOMMEND THAT YOU WRITE THE DATA HERE:

Model (MOD.) .....

Product number (PNC) .....

Serial number (S.N.) .....

# INSTALLATION

## **⚠ WARNING!**

Refer to Safety chapters.

## Location of the appliance

You can install your freestanding appliance with cabinets on one or two sides and in the corner.



Keep a distance of about 1 cm between the appliance and the back wall to make sure that the lid opens.

For minimal distances for fitting check the table.

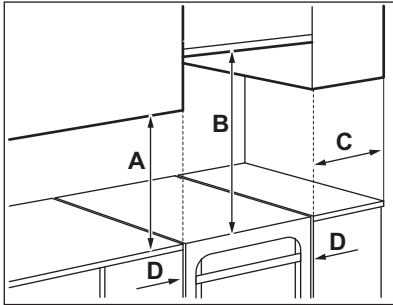

## Other technical data

Appliance category:

I3B/P

Gas original:

G30 (3B/P) 28-30 mbar

## Bypass diameters

### BURNER

### Ø BYPASS 1/100 MM

Auxiliary	29
Semi-rapid	32
Rapid	42
Oven	50
Grill	59

## Minimum distances

DIMENSION	MM
A	400
B	650
C	150
D	20

## Technical data

Voltage	220 - 240 V
Frequency	50 - 60 Hz
Appliance class	1

DIMENSION	MM
Height	850 - 870
Width	600
Depth	600

## Gas burners for LPG G30 28-30 mbar

BURNER	NORMAL POWER KW	GAS RATE G/H	REDUCED POWER KW	INJECTOR MARK 1/100 MM
Rapid	3.0	218.1	0.72	88
Semi-rapid	1.85	134.5	0.43	71
Auxiliary	0.95	69.1	0.35	50
Oven	2.25	163.6	1.0	71
Grill	2.0	145.4	1.5	71

## Gas connection

### ⚠ WARNING!

Before you connect the gas, disconnect the appliance from the electricity supply or switch off the fuse in the fuse box. Close the primary valve of the gas supply.

The gas pipe in the appliance has two endings. You can connect the gas supply to either one of them. The pipe that is not used must be clogged with the pipe closer, which added to the appliance.

Use a fixed connections or use a flexible stainless steel pipes in compliance with the regulation in force. If you use flexible metallic pipes, make sure they do not come in touch with mobile parts and they are not squeezed.

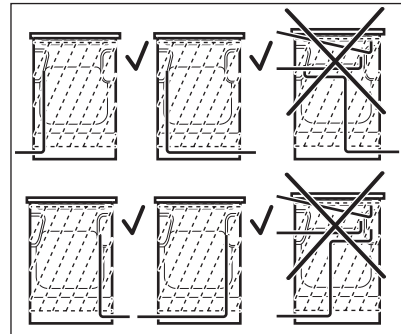

### ⚠ WARNING!

When installation is complete, make sure that the seal of each pipe fitting does not leak. To check the seal use a soap solution, not a flame.

## Flexible nonmetal pipes connection

If you have an easy access to the connection, you can use a flexible pipe. The flexible pipe must be tightly attached by clamps.

In installation always use the pipe holder and the gasket. The flexible pipe can be applied when:

- it can not get hotter than room temperature, higher than 30 °C,

# INSTALLATION

- it is not longer than 1500 mm,
- it has no narrowing anywhere,
- it is not twisted or tighten,
- it does not get in touch with sharp edges or corners,
- it's conditions can be easily checked.

When checking the flexible pipe make sure:

- it does not show cracks, cuts, marks of burnings on the two ends and on its full length,
- the material is not hardened, but shows its correct elasticity,
- the fastening clamps are not rusted,
- expired term is not due.

If one or more defects are visible, do not repair the pipe, but replace it.

The gas supply ramp is on the rear side of the control panel.

## Levelling

### ⚠ CAUTION!

Remove all the accessories from the oven.

1. Open the lid of the appliance and disassemble it.
2. Disassemble the pan supports and all the burner assemblies.

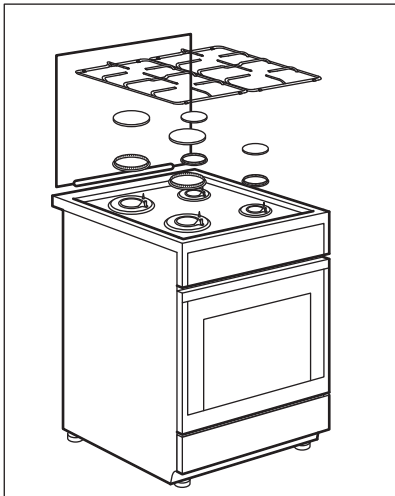

3. Put the appliance on the sidewall on a clean and smooth surface. Place each foot into a separate hole, in the plinth, and rotate it clockwise.

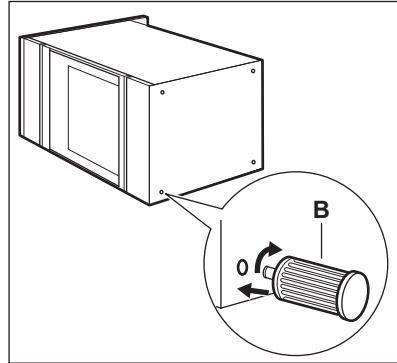

4. If the floor is not equally flat, use the adjustable feet on the bottom of the appliance to set a stable position for the appliance.

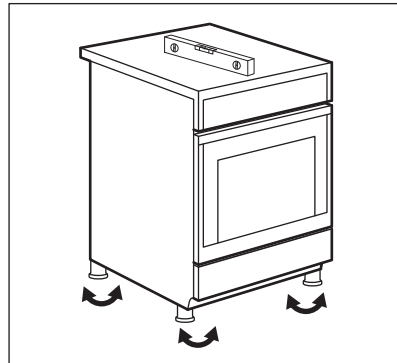

To install all the accessories, do the first step in an opposite sequence.

## Electrical installation

### ⚠ WARNING!

The manufacturer is not responsible if you do not follow the safety precautions from Safety chapters.

This appliance is supplied with a main plug and a main cable.

## **⚠ WARNING!**

The power cable must not touch the part of the appliance shaded in the illustration.

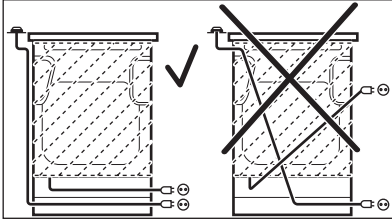

## ENVIRONMENTAL CONCERNS

Recycle materials with the symbol . Put the packaging in relevant containers to recycle it. Help protect the environment and human health by recycling waste of electrical and electronic appliances. Do not

dispose of appliances marked with the symbol  with the household waste. Return the product to your local recycling facility or contact your municipal office.









